An Introduction to Air Quality and Auxiliary Equipment for Boiler Plants

Course No: M04-039

Credit: 4 PDH

J. Paul Guyer, P.E., R.A., Fellow ASCE, Fellow AEI



Continuing Education and Development, Inc.
22 Stonewall Court
Woodcliff Lake, NJ 07677

P: (877) 322-5800
info@cedengineering.com

An Introduction to Air Quality and Auxiliary Equipment for Boiler Plants



J. Paul Guyer, P.E., R.A.
Editor

Paul Guyer is a registered civil engineer, mechanical engineer, fire protection engineer, and architect with over 35 years of experience in the design of buildings and related infrastructure. For an additional 9 years he was a senior advisor to the California Legislature on infrastructure and capital outlay issues. He is a graduate of Stanford University and has held numerous national, state and local positions with the American Society of Civil Engineers, Architectural Engineering Institute and National Society of Professional Engineers.

CONTENTS

- 1. AIR QUALITY CONTROL AND MONITORING**
- 2. AUXILIARY MECHANICAL EQUIPMENT**
- 3. STEAM DEAERATORS**
- 4. BOILER FEED PUMPS**
- 5. CONDENSATE PUMPS**
- 6. AIR COMPRESSORS**
- 7. BOILER FEEDWATER TREATMENT**
- 8. BLOWDOWN TANK**
- 9. BLOWDOWN HEAT RECOVERY**
- 10. STEAM COIL AIR HEATER**
- 11. STEAM COIL DRAIN TANK**
- 12. FANS**
- 13. HYDRAULIC ASH HANDLING PUMPS**
- 14. ELECTRIC COOLING WATER PUMPS**
- 15. BEARING COOLING WATER HEAT EXCHANGERS**
- 16. IGNITOR FUEL OIL PUMPS**
- 17. NITROGEN SYSTEM**
- 18. CARBON DIOXIDE (CO₂) SYSTEM**
- 19. CHEMICAL FEED PUMPS**
- 20. LABORATORY**
- 21. SUMP PUMPS**

(This publication is adapted from the Unified Facilities Criteria of the United States government which are in the public domain, have been authorized for unlimited distribution and are not copyrighted.)

1. AIR QUALITY CONTROL AND MONITORING

1.1 GENERAL. This publication provides an introduction to air quality control and monitoring equipment for fuel fired plants such as steam boiler plants.

1.2 PARTICULATE CONTROL SYSTEMS. The types of particulate control systems which are commonly used are mechanical cyclone collectors, fabric filter baghouses and electrostatic precipitators.

1.3 FLUE GAS DESULFURIZATION SYSTEMS. The dry and wet types of flue gas desulfurization (FGD) systems are commonly used to remove sulfur oxides from the boiler flue gas.

1.4 NITROGEN OXIDE (NO_x) CONTROL SYSTEMS. Two types of systems available for NO_x emissions reduction are selective catalytic reduction (SCR) and selective noncatalytic reduction (SNCR). SCR systems require periodic replacement of the catalyst. SNCR removal efficiency is maintained only within a narrow temperature range.

1.5 AIR MONITORING EQUIPMENT.

1.5.1 GENERAL. Federal regulations require new sources to obtain and maintain acid rain permits. A permit is good for five years and must be renewed. Emission allowances are required to emit sulfur dioxide. Pollutants must be monitored to verify compliance with the acid rain program. Reported values include SO₂ (lb/hr), NO_x (lb/MB), CO₂ (lb/hr), excess opacity (percent), and heat input (MB). Measurement options are available to gas/oil fired units, depending upon the type or category of gas/oil unit. Exemptions from acid rain permit requirements including exemptions from continuous emissions monitoring (CEMS) are available to certain types and sizes of emitters by

petition. A thorough investigation of local, state, and federal regulations is required for each new source.

1.5.2 CEMS COMPONENTS. CEMS include four major components or subsystems. Gas monitors measure the concentration of pollutants at a particular point in the flue gas stream. Flow monitors measure flue gas flow and fuel flow monitors measure natural gas and fuel oil flow rate. Opacity monitors indicate the emission of particulate matter from the stack. The data acquisition system (DAS) stores monitored information, performs necessary calculations and generates the required reports.

1.5.3 GAS MONITORS. Gas monitors can be classified as either in situ or extractive.

1.5.3.1 IN SITU ANALYZERS are attached directly to the probe on the stack or breeching. Access for routine maintenance is required and personnel weather protection may also be desirable for outdoor installations depending upon the climate. In situ monitors relay information to the DAS using 4 to 20 mA signals.

1.5.3.2 EXTRACTIVE MONITORS pull samples from the flue gas stream using stack or breeching probes. The flue gas sample is then transported to the cabinet mounted analyzer located on the plant floor or ground level as required. This cabinet is placed to provide convenient access for operation and maintenance. The interior of the cabinet can also include any necessary heating, air conditioning or humidity control. Extractive systems are further classified as either wet, dry or dilution. Since raw samples contain SO₂ and moisture, ambient cooling of wet samples will cause condensation of sulfuric acid. For longevity of the equipment wet sample tubes must be heated to avoid acid corrosion. Removal of water from the sample using a cooler provides a dry sample which no longer requires heating. These systems are called dry extractive. Dilution extractive systems use clean dry air to dilute the sample gas in the probe from between 50 to 200 times. This diluted sample eliminates the need for heat traced sample lines,

pumps, filters or dryers. Analyzers are readily available to accurately and reliably measure diluted pollutant concentrations.

1.5.4 FLUE GAS FLOW MONITORS. Monitoring of flue gas flow is sometimes required. In these cases flue gas flow is used along with the primary measured value to calculate the reported value. Three types of flue gas flow monitoring systems that have been used include ultrasonic monitors, thermal monitors and differential pressure monitors.

1.5.4.1 ULTRASONIC FLOW RATE MONITORS. Ultrasonic flow monitors consist of two ultrasonic transducers mounted at different elevations and on opposite sides of the stack. This type of monitor measures the time required for an ultrasonic pulse to travel from the downstream transducer to the upstream transducer. The speed of sound in the flue gas stream and the flue gas stream temperature are determined from the average of these two measurements. The velocity of the flue gas stream is determined from the difference between the measurements. An input signal from the plant barometer can be provided so that flow rate can be calculated in standard cubic feet per minute. Automatic zero checks of ultrasonic flow monitors are conducted by sending successive pulses in the same direction. Span checks are conducted by again firing successive pulses in the same direction, but with a time delay between the pulses which represents a specific flue gas flow velocity.

1.5.4.2 THERMAL FLOW RATE MONITORS. Thermal flow monitors depend on temperature measurements and thermal properties of the flue gas. There are two types of thermal measurement. One type measures the temperature difference between two similar resistance temperature devices (RTD), one is heated at a constant rate and the other is unheated. The temperature difference will be a function of the velocity of the flue gas. The higher the velocity, the greater the cooling effect, and hence the smaller the temperature difference. The other type of thermal probe varies the current to the heated element as necessary to maintain a constant temperature difference. The higher the velocity of the flue gas, the greater the heat rate required to maintain the

temperature differential. Zero and span checks of these devices require their removal from service. Techniques for conducting DAS automatic daily calibration drift tests have not yet been developed.

1.5.4.3 DIFFERENTIAL PRESSURE FLOW MONITORS. Differential pressure flow monitors use the pitot tube principle to measure the flow. A pitot tube is a device which measures both the static pressure and the impact pressure created by the flue gas. The square root of the difference in these two pressures is a function of the gas velocity. Types include single point and across-the-duct averaging. One version of the averaging pitot probe has a diamond shaped cross-section and multiple impact and static pressure taps along the length of the probe. Standard differential pressure transmitters are used to sense the difference between the static and total pressure. These devices are simple and use standard pressure transmitters. In high particulate applications, a purge system may be needed to keep the pitot pressure taps clear. Zero checks are accomplished by pneumatically connecting the two sides of the pressure transmitter. These checks can easily be automated for daily zero drift checks. Span checks can be performed by using a water manometer. This type of span procedure is more difficult to automate.

1.5.5 OPACITY MONITORS. Opacity monitors use the principle of transmissometry to indicate the level of particulate emissions. A beam of light is projected across the flue gas stream. A measurement detector registers variations in the light transmittance caused by the amount of particulate in the flue gas.

1.5.6 DATA ACQUISITION SYSTEMS. Data acquisition systems (DAS) typically consist of personal computers (PC). A typical system includes a central processing unit (CPU), hard disk drive, a floppy disk drive, a keyboard, a cathode ray tube (CRT) or TV screen and a printer. Serial ports and required software are included to accept the input signals from the monitoring equipment. The hard disk drive provides magnetic storage of data and allows quick access for rapid calculation. The floppy disk drive allows storage of years of historical data in more than one remote location which decreases

the risk of losing this information while at the same time provides rapid regeneration of past reports. The printer provides hard copy of all data while the keyboard and CRT allow operator interface. The DAS performs several tasks. Signals from the monitors must be interpreted and stored. This data is stored in the form of ASCII files. A continuous readout of emissions in the required measurement units is produced. The DAS performs monitor calibration errors and bias adjustments. Missing data procedures are also computed and recorded by the DAS. Required reports are also generated by the DAS.

1.5.7 REGULATORY REQUIREMENTS. The regulations include several specific equipment requirements. These include span values, calibration capabilities, calibration error limits, relative accuracy, bias limits, calibration gas quality and cycle response time.

(1) Proper monitor location for specific installations is essential. The final location must be representative of total emissions, must pass the relative accuracy (RA) test and must meet point/ path requirements as outlined in the regulations. Location has to provide representative flow over all operating conditions. This requires that the velocity at sample point be representative of the average velocity over the cross section. Emission rate in terms of lb/MB must reflect actual emissions. Monitor location must also represent actual pollutant concentration. Location has to minimize the effects of condensation, fouling and other adverse conditions. Tests are also required to determine the acceptability of the location and to also determine the number and location of flow monitor points.

(2) There are specific reporting requirements that have to be addressed. Notification must be given to governing federal, state and local agencies prior to certification and recertification tests. A monitoring plan must be established. Applications have to be submitted for certification and recertification tests. Quarterly reports and opacity reports are also mandatory.

(3) The monitoring plan although not part of the GEMS specifications has several elements that are common to both. Monitoring plans include pre-certification information, unit specific information, schematic stack diagrams, stack and duct engineering information, monitor locations, monitoring component identification table, DAS table and emissions formula table.

(4) Records have to be maintained for at least three years. Record keeping includes date, hour, unit operating time, integrated hourly gross unit load, operating load range and total heat input in MMBtu.

(5) The certification tests have to be successfully executed on time. These tests include a 7 day calibration error test for gases and flow, a linearity check, cycle time/response time test, relative accuracy test and bias test. Guidelines clearly outline whether or not recertification tests are required when changes have been made to equipment, location or the DAS.

(6) Quality assurance and quality control procedures must be developed into a well defined program which includes calibration error testing and linearity checking procedures, calibration and linearity adjustments, preventative maintenance auditing procedures or relative accuracy test audit (RATA). Calibration error tests have to be performed on a daily basis. SO₂ and NO_x monitors must be challenged by zero level and high level calibration gases. The measured values must be within 2.5 percent of the cal gas value. If the span is less than 200 ppm then the values must be within 5 ppm. CO or O₂ monitors also have to be challenged by zero level and high level calibration gases. For these monitors the measured value be within 0.5 percent of the cal gas value. Flow test is required. Flow monitors are required to zero at 20, 50 and 70 percent of span. The measured values have to be within 3 percent of the referenced value. Linearity checks are required quarterly. These checks must use dedicated low, mid and high level cal gases. Measured values must be within 5 percent of the cal gas value. Average difference among three nonconsecutive checks with each cal gas must be less

than or equal to 5 ppm for SO₂ and NO_x or less than or equal to 0.5 percent of CO₂ or O₂.

(7) Several daily adjustments are required. Error adjustments on gas and flow monitors are required daily. Recalibration must then be performed after each adjustment. A flow monitor interference check is necessary. This includes sample sensing line port pluggage and RTD/transceiver malfunction. An out of control period is when calibration error exceeds two times the calibration error limit or when flow fails interference check. Data recording must include unadjusted values and magnitude of adjustment.

(8) Quarterly adjustments are also required. Linearity must be checked on a quarterly basis when no adjustments are made. Leak checks are required for differential pressure monitors. An out of control period is when linearity exceeds limit on any test run or when a flow leak is detected.

(9) Preventive maintenance procedures must be in writing, including equipment manufacturer*s recommendations. A schedule for the implementation of these procedures has to be maintained. An inventory of spare parts is also required.

(10) A relative accuracy test audit (RATA) is required semi-annually unless accuracy is better than 7.5 percent. The RATA has to be performed during a 7 day period. A minimum of 9 sets of reference method test data are needed. One set of data consists gas sample must be analyzed for concentrations or flow using the reference methods. Calculations must include determinations of the mean, standard deviation, confidence coefficient and bias. A flow test is required.

2. AUXILIARY MECHANICAL EQUIPMENT

2.1 GENERAL.

This section addresses the criteria for the major steam plant auxiliary equipment.

2.2 CLOSED FEEDWATER HEAT EXCHANGERS (CFHE).

2.2.1 APPLICATIONS. CFHE may be used to raise feedwater temperature to the plant economizer and thus maintain the exit flue gas temperature above the acid dew point during low load operation. This application is possible for plant design in all size ranges. Other methods for keeping the exit flue gas temperature above the acid dew point are bypassing flue gas around the economizer or bypassing a portion of feedwater around the economizer which needs to be avoided. Bypassing the feedwater around the economizer at low load operation creates a potential for steam formation in the economizer. The CFHE is the most positive approach to maintaining the existing flue gas temperature. An evaluation will be made to determine the economic practicality of each method.

2.2.2 CFHE DESIGN. Each CFHE will be a U-tube type heater to minimize stresses caused by thermal expansion. Tube material selection is dependent on the quality of the water. Tubes of stainless steel construction will minimize the possibility of corrosion and erosion. High quality water will allow the use of 90/10 and 70/30 copper nickel (CuNi) material tubing.

2.2.3 CFHE DESIGN CRITERIA. Data listed in table 1 are necessary to size CFHE.

<i>Parameter</i>	<i>Engineering Units</i>
Feedwater flow	pph
Feedwater inlet temperature	degrees F
Feedwater outlet temperature	degrees F
Maximum feedwater velocity	fps
Maximum allowable tube side pressure drop	psi
Maximum tube side operating pressure	psig
Maximum shell side operating pressure	psig

Table 1
Closed Feedwater Heat Exchanger Design Parameters

Minimum recommended feedwater temperatures to the economizer are shown in Figure 1. Minimum feedwater velocities are shown in Figure 2.

3. STEAM DEAERATORS.

3.1 GENERAL. The steam deaerator (DA) heats boiler feedwater to improve plant efficiency and lowers dissolved oxygen and gasses that are corrosive to internal metal surfaces of the boiler. The standards of the Heat Exchange Institute (HEI), 1992, Fifth Edition, state that a DA should be guaranteed to remove all dissolved oxygen in excess of 0.005 cc/i.

3.2 DEAERATOR TYPES. There are several types of steam DA with three acceptable types being: spray/tray type, atomizer or scrubber spray type and recycle type. DA heater should be counterflow design. Although some tray and recycle type DA*s have a higher first cost, they will operate properly under rapid load changes and only require a 10 to 30 degrees F rise across the DA (inlet water temperature 10 to 30 degrees F lower than the DA outlet water temperature). Spray or atomizing type DA's can be used when steam loads are steady and the temperature rise across the DA is 30 to 50 degrees F or greater. Because of this performance limitation, tray or recycle type DA*s will be used unless there is a steady steam load and the temperature rise in the DA is 50 degrees F or greater. If the latter conditions exist, the DA selection will be decided by a LCCA.

3.3 DEAERATOR DESIGN CRITERIA. Deaerating heaters and storage tanks will comply with the ASME Unfired Pressure Vessel Code, ASME Power Test Code for Deaerators, Heat Exchange Institute, American National Standards Institute, and National Association of Corrosion Engineers Recommendations. One steam plant DA can be sized for multiple boiler units. At full load conditions, the water from the DA will have a temperature sufficiently high to prevent acid dew point corrosion of the economizer. In no case will the temperature rise in the DA be less than 20 degrees F or the minimum storage capacity at normal operating level be less than 10 minutes at the DA*s maximum continuous load rating or less than 12 minutes full. Information

contained in table 2 will be specified after a heat balance around the DA has been determined at full load conditions.

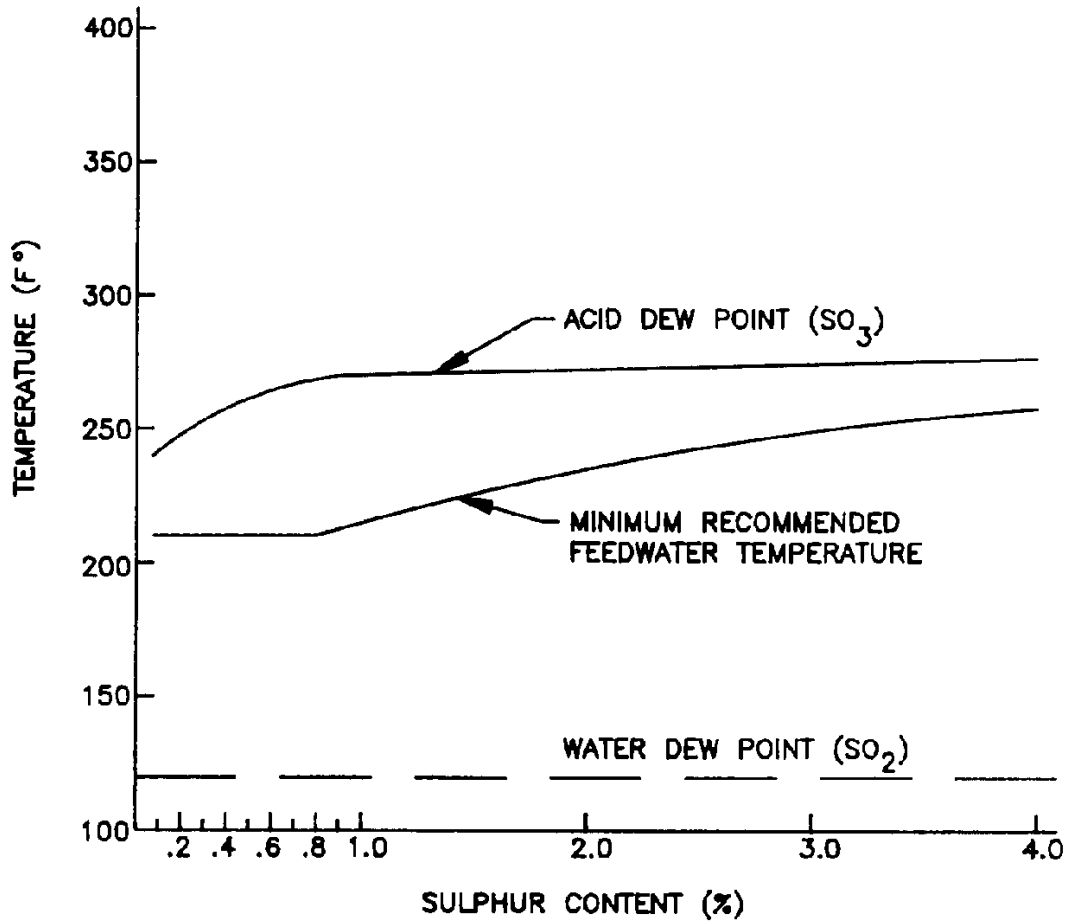

Figure 1
Minimum recommended feedwater temperatures

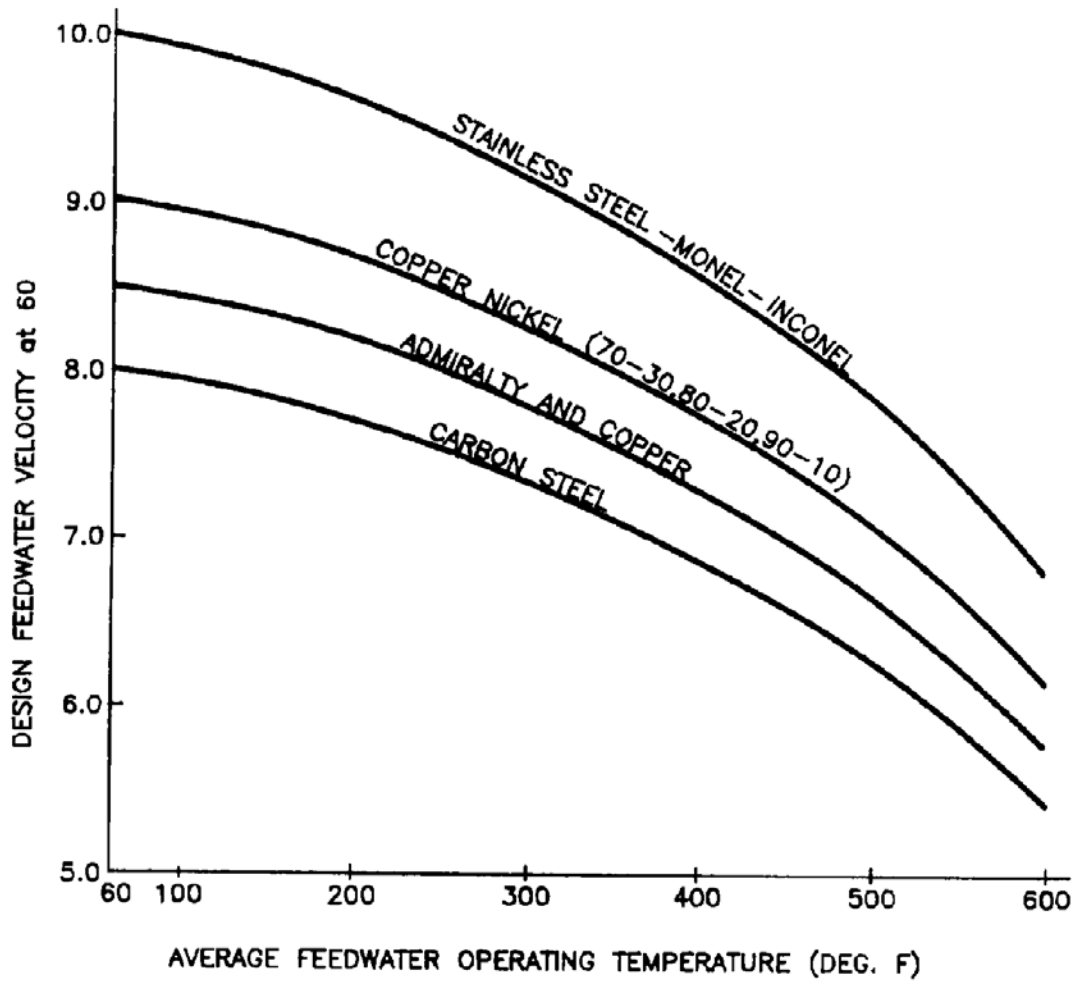

Figure 2

Design feedwater velocity at 60 deg F

<i>Item</i>	<i>Engineering Units</i>
Maximum plant capacity	pph
Maximum DA outlet capacity	pph
Make-up water temperature	degrees F
Condensate temperature	degrees F
Make-up water flow	pph
Condensate flow	pph
Steam temperature to DA	degrees F
Steam pressure to DA prior to control valve	psig
DA design pressure	psig
DA outlet water temperature	degrees F
DA outlet water flow	pph

Table 2
Specified deaerator information

4. BOILER FEED PUMPS.

4.1 GENERAL. Boiler feed pumps convey water from the DA to the boiler.

4.2 DESIGN REQUIREMENTS. Boiler feed pumps will comply with the latest revisions of Hydraulics Institute (HI) and ANSI. A minimum of one pump per boiler and one backup pump will be provided for all cases. The ASME Boiler and Pressure Vessel Code requires that coal fired boiler plants in this size range be provided with at least two means of feeding water. For stoker fired boilers, one source will supply sufficient water to prevent boiler damage during an interruption. A steam turbine driven pump is one method that is frequently used to meet this requirement. Multiple pumps permit backup capacity for individual pump failures or scheduled maintenance and increase efficiency of pump operations at reduced loads. Multiple pumps are usually more cost effective for boilers subjected to large daily load swings. This arrangement allows the pumps to operate in a more efficient range and gives the system more flexibility. The use of multiple pumps will provide for between 50 and 100 percent of additional capacity beyond the expected operating loads.

4.3 STEAM TURBINE DRIVES VS ELECTRIC MOTOR DRIVES. Steam turbine drives provide a more thermally efficient system, but in this size range they can be less economical on a LOCA than electric motor drives. However, as noted above, the ASME Boiler and Pressure Vessel Code requires that both steam turbine and motor drives be used in stoker fired boiler plants with capacities of 35,000 pph and above. Steam turbine drives will not be used exclusively. An electric motor drive makes it easier to bring a boiler on line from a cold start.

4.4 BOILER FEED PUMP SIZING. Boiler feed pumps will be sized to deliver the desired flow and pressure to the boilers from the DA. A 10 percent flow margin for wear allowance will be included when sizing the pump. These conditions are determined by first defining the items listed in table 3.

<i>Item</i>	<i>Engineering Units</i>
Boiler steam outlet pressure	psig
Boiler water side pressure losses	psi
Water temperature entering pump	degrees F
Piping losses	psi
DA operating pressure	psig
Pump elevation relative to boiler and DA	ft
Net positive suction head required (NPSHR)	ft

Table 3
Boiler Feed Pumps Capacity Criteria

4.4.1 CALCULATION OF NET POSITIVE SUCTION HEAD AVAILABLE (NPSHA).

Determining the NPSHA is an important design consideration for boiler feed pumps because they take water from the DA at saturated conditions. To prevent cavitation of a pump operating at elevated temperatures, the DA is elevated to increase the static pressure at the pump suction and overcome the vapor pressure. The boiler feed pump vapor pressure is equal to the DA operating pressure and cancel out each other. Thus, boiler feed pump NPSHA is the head of water from the DA to the pump inlet minus the pipe friction loss. A safety margin of at least one foot of head will be subtracted from the calculated NPSHA to obtain the net positive suction head required (NPSHR).

4.4.2 DISCHARGE HEAD CALCULATION. The boiler feed pump discharge head will be designed to overcome the boiler drum pressure, valve and piping losses within the boiler and external to the boiler as well as the head of the water column.

4.5 PUMP CONSTRUCTION. The boiler feed pumps will be constructed to provide continuous operation for the expected plant life. Pump manufacturers should be

consulted regarding specific features of construction for a particular application. In general, lower pressures and flows could use vertical in-line pumps with stainless steel shaft, impellers, and impeller casings. Suction and discharge chambers on vertical pumps will be cast iron. For higher pressure and flow applications casings will be 11 to 13 percent chrome steel, split on the horizontal centerline with suction nozzles, discharge nozzles and feet on the lower half of the casing so the top half of the casings can be removed without disturbing the main piping. These applications will also include shafts constructed of stainless steel, containing not less than 11 percent chrome. The impellers will be of the closed type, cast in one piece. All internal parts of the pumps including impellers, sleeves and wearing rings, will be constructed of stainless steel containing not less than 11 percent chrome.

5. CONDENSATE PUMPS.

5.1 GENERAL. The condensate pumps convey condensate from condensate return storage tank to the DA.

5.2 DESIGN REQUIREMENTS. A minimum of two condensate pumps will be used, each sized for at least two thirds of the maximum steam plant demand. This configuration will provide backup capacity for individual pump failures or scheduled maintenance and will increase pump operation efficiency at reduced loads. Steam turbine driven pumps may be more economical than electric motor driven pumps. However, one electric motor driven pump facilitates cold start-up of the boiler plant. A LCCA will be made to determine the most practical combination of condensate pumps.

5.3 CONDENSATE PUMP SIZING. The condensate pump discharge head needs to be designed to overcome the water static head to the DA, the piping losses and the DA operating pressure. A 10 percent flow margin for wear allowance will be included when sizing the pump. The condensate pump discharge head and suction head available will be determined when the operating conditions are defined, an arrangement of the equipment has been made, and a pipe size and routing has been made.

5.4 PUMP CONSTRUCTION. Pumps will be constructed so they will provide continuous operation for the expected plant life. Pump manufacturers should be consulted regarding specific features of construction for a particular application. The pump impellers will be split ring key type. Bearings will be of the water lubricated sleeve type. The baseplate, outer barrel, inner column and discharge head will be carbon steel. The impeller will be bronze and the pump bearings graphalloy. The stage bowl will be cast iron. The shaft, shaft sleeves and wearing rings will be 11 to 13 percent chrome stainless steel. When the pump design conditions do not require a vertical can type pump as described above, the pump may be centrifugal, horizontal end suction, top discharge type as described below. The pump impellers will be totally open type, screw

mounted directly to the shaft with O-ring seal and constructed of ductile iron. Impellers will be dynamically balanced to the maximum rated speed. The pump construction will include antifriction bearings that operate in an oil bath. Pump and bearing frame and housing will be constructed of cast iron. Casing will be constructed of ductile iron. Minimum casing thickness will be ½ inch with an additional 1/8 inch corrosion allowance. The shaft, shaft sleeves and wearing rings will be 316 stainless steel.

5.5 TURBINE DRIVES. The turbine drives will be sized to match the runout hp of the pump. Turbine drives will be horizontal split case construction. The steam chest will be annealed carbon steel and the rotor disc a high strength alloy steel.

6. AIR COMPRESSORS.

6.1 APPLICATIONS. Two compressor applications are used in a steam plant: plant air and instrument air. Plant air is the dry air used to atomize fuel oil, blow soot deposits from the boiler furnace and heat recovery equipment, run plant pneumatic tools, and perform other general plant functions. Instrument air is oil free, dry air supplied to instruments and pneumatic controls control valves and control drives. Instrument air is also used to clean fly ash baghouse filter bags.

6.2 COMPRESSOR TYPES. Compressors are available in two types. The first type is positive displacement, such as the reciprocating piston compressor. The second type is dynamic, such as the centrifugal compressor. Each type can be furnished with single stage or multiple stage design. Reciprocal and centrifugal compressors are the industry standard for compressors used in boiler plants. Centrifugal compressors are usually considered for selection when the compressed air demand is uniform and is equal to or above 400 standard cubic feet per minute (scfm). Otherwise reciprocating compressors are usually used.

6.3 INSTRUMENT AIR COMPRESSOR SIZING CRITERIA.

6.3.1 REQUIRED VOLUME OF AIR. The required volume of air needed is found by adding all simultaneous air usages together. With instrument air, the highest usages generally occur during boiler start up when lighters are inserted or when fly ash baghouse filter bags are being cleaned.

6.3.2 OUTLET PRESSURE. The compressor outlet pressure will be sufficient to supply air at the required pressure, after line losses, to the device requiring the highest pressure in the instrument air system. Pressure regulators will limit the pressure to devices operating at lower pressures.

6.4 PLANT AIR COMPRESSOR SIZING CRITERIA.

6.4.1 REQUIRED VOLUME OF AIR. The required volume of air needed is found by adding all simultaneous air usages together. One of the highest usages of plant air occurs when air soot blowers are used in the boiler. Steam soot blowers may be used eliminating the need for air soot blowers. Other usages which must be considered are air tool demand and cleaning coal handling dust bags.

6.4.2 OUTLET PRESSURE. The compressor outlet pressure will be sufficient to supply air at the required pressure, after line losses, to the device requiring the highest pressure in the plant air system. Pressure regulators will limit the pressure to devices operating at lower pressures.

6.5 COMPRESSOR AUXILIARIES.

6.5.1 AFTERCOOLERS/INTERCOOLERS. Intercoolers are used on any compressor having more than one stage, and all compressors will have aftercoolers. Aftercoolers will be pipeline type units with air-in-tube, water-in-shell construction and designed with a 20 degrees F approach.

6.5.2 AIR DRYERS. All air compressors will have air dryers installed immediately downstream of the aftercoolers. The dryers will be designed to maintain a dew point at line pressure which is lower than any ambient temperature to which pressurized air lines are exposed.

6.5.3 RECEIVERS. Receivers will be sized based upon a timed usage of a volume of air. The required tank volume will be determined using the following equation:

$$T = \frac{V \times (P_1 - P_2)}{C \times P_0}$$

- T = time in minutes receiver will supply air from upper to lower pressure limits (use 15 seconds)
- V = volume of tank, in cubic feet
- P₀ = absolute atmospheric pressure, psia
- P₁ = maximum tank pressure, psia (compressor discharge pressure)
- P₂ = minimum tank pressure, psia (pressure required to operate tool)
- C = amount of cubic feet of free air needed per minute, cfm (air at ambient temperature and pressure)

6.6 GENERAL DESIGN CRITERIA.

6.6.1 THE TOTAL AIR CAPACITY will be increased by a factor of 1.1 to 1.2 to account for leakage.

6.6.2 BOTH THE INSTRUMENT AIR AND THE PLANT AIR SYSTEMS will consist of two compressors tied to a common header. Backup capacity of 100 percent will be provided so maximum compressed air demand can be satisfied with one compressor out of service.

6.6.3 THE HEADERS FOR INSTRUMENT AIR AND PLANT AIR will have an emergency cross-connection equipped with oil removal equipment to protect the instrument air system.

6.6.4 PLANT AIR COMPRESSOR will be designed to be loaded 50 percent of the time at maximum load. Instrument air compressor is to be sized for 40 percent loading at maximum load. Centrifugal compressors can be loaded 100 percent of the time.

6.6.5 PROVISIONS will be made to allow drainage of water from all coolers and receivers by means of traps or manual valving.

6.6.6 SEPARATE RECEIVERS will be placed near area of large air demands. It may be more economical to supply separate air systems for air soot blowers and baghouse cleaning systems.

7. BOILER FEEDWATER TREATMENT.

7.1 GENERAL. Feedwater treatment is necessary to prevent corrosion of metals, formation of deposits and to minimize boiler water solids carryover. For boilers operating at 400 psig, constituents in the feedwater must be controlled so that the maximum water limits for boiler feed-water and boiler water shown in tables 4 and 5 can be maintained with minimal boiler blow-down, since the higher the blowdown rate, the greater the thermal loss. An evaluation will be made to determine the costs of thermal losses due to blowdown versus the costs of high quality treated water.

<i>Drum Pressure (psig)</i>	<i>Iron (ppm Fe)</i>	<i>Copper (ppm Cu)</i>	<i>Total hardness</i>
			<i>Calcium carbonate (ppm CaCO₃)</i>
0 – 300	0.100	0.050	0.300
301 – 450	0.050	0.025	0.300

Table 4
Boiler feedwater limits

<i>Drum Pressure (psig)</i>	<i>Silica silicon</i>	<i>Total Alkalinity</i>	<i>Specific conductance (micromhos./cm)</i>
	<i>dioxide (ppm SiG)</i>	<i>calcium carbonate (ppm CaCO₃)</i>	
0 – 300	150	700	7000
301 – 450	90	600	6000

Table 5
Boiler water limits

7.2 DESIGN REQUIREMENTS. Before a plant water treatment system is designed, a thorough raw water analysis will be obtained as shown in table 6. The raw water condition can vary widely even within a small regional area and can greatly affect the options and economics available for water treatment equipment. Also, the purity and quantity established. From this information the actual feedwater constituents to be treated can be determined. The water treatment requirements for the plant can then be identified based on the allowable boiler water limits and the desired amount of continuous boiler blowdown (use 1 percent of boiler maximum continuous rating as a starting blow-down value).

<i>Water properties</i>	<i>Milligrams/Liter As the ion or as Shown</i>
Calcium	64.5
Silica	9.1
Magnesium	20.7
Sodium	70.0
Sulfate	182.0
Chloride	23.3
Bicarbonate	211.0
Nitrate	4.0
Total hardness	248.0
Carbonate hardness	173.0
Noncarbonate hardness	73.0
Total alkalinity	166
Conductivity - microseim per per centimeter	731
pH	8.2

Note: Water characteristics will vary by location.

Table 6
General Raw Water Analysis.

7.3 TREATMENT. Water treatment is generally categorized by external treatment or internal treatment. External treatment dampens, softens, or purifies raw water prior to introducing the water into the feedwater system. Internal methods introduce chemicals directly into the feedwater or boiler water where they regulate the undesirable effects of water impurities. Blowdown is used in the evaporative process to control the concentration of dissolved and suspended solids. Methods of water treatment include filtration (reverse osmosis), deaeration and degasification, cold or hot lime softening, sodium zeolite ion exchange, chloride cycle dealkalization, demineralization, internal chemical treatment, and blowdown. Several internal treatment methods commonly used to treat boiler water include phosphate hydroxide or conventional treatment method, chelent method, polymer method (feedwater < 1.0 ppm Ca as CaCO₃) and coordinated phosphate/pH (high purity # 15 microhms conductivity). These chemical internal treatment methods can be used in conjunction with external treatment methods. After a raw water analysis has been made, a water treatment specialist should be consulted and an evaluation should be made on the practicability of a combination of internal and external treatment methods. It is usually more cost effective to externally pretreat the feedwater as much as practical. This discussion concerns boiler feedwater treatment equipment. It is assumed that water delivered to the feedwater equipment is of a pretreated, clear, potable quality free of organic materials.

7.4 BOILER FEEDWATER TREATMENT EQUIPMENT. The industry standards for reducing water constituents in boilers with an operating pressure of 400 psig are reverse osmosis, ion exchangers, or combinations of the two.

7.4.1 REVERSE OSMOSIS (RO) is a filtration method which removes approximately 90 percent of all inorganic dissolved solids from the feedwater. Reverse osmosis can be used alone, as shown in figure 3, but is more generally used with regenerative ion exchange equipment (demineralizer) shown in figure 4. The viability of using reverse osmosis will be determined by a LCCA.

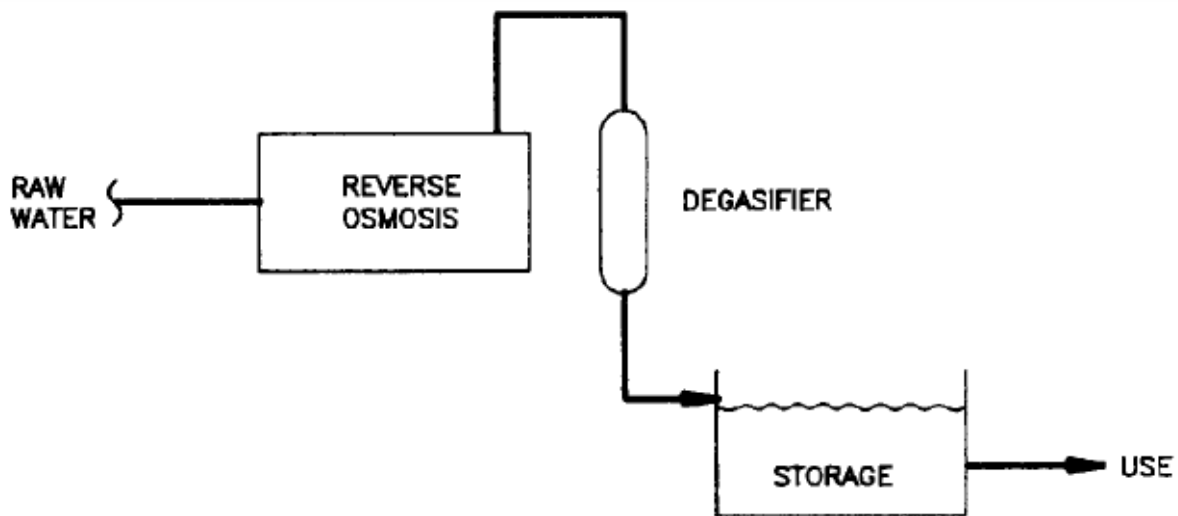

Figure 3

Boiler feedwater treatment with reverse osmosis only

7.4.2 SODIUM ZEOLITE (NAZ) SOFTENERS are used to remove calcium (Ca) and magnesium (Mg) from the feedwater. NaZ softeners do not remove silica, bicarbonate, or carbonate, in the boiler feedwater. A typical NaZ softener is shown in figure 5.

7.4.3 A SPLIT STREAM SOFTENER with degasifier should be used when it is necessary to remove hardness (Ca, Mg) and carbon dioxide (CO₂) formed from bicarbonate and carbonates. A typical split stream system is shown in figure 6. The use of split stream versus other options will be decided by means of a LCCA and an evaluation of applicable safety restrictions. This particular type system will result in a reduction of total dissolved solids (TDS).

7.4.4 CHLORIDE ANION EXCHANGERS (DEALKALIZER) may be used in conjunction with NaZ softener to remove carbonate, bicarbonate and Used in this manner, the dealkalizer takes the place of a hydrogen cycle softener and degasifier in the split stream system. A dealkalizer application is shown in figure 7. This particular type system will not reduce TDS.

7.4.5 A WEAK CATION EXCHANGER, regenerated with acid, followed by a strong acid cation exchanger, salt regenerated, can be used in conjunction with a degasifier. The weak acid exchanger will remove the alkalinity and the hardness associated with alkalinity, and the salt regenerated strong acid cation exchanger will remove the balance of the hardness. This balance will depend on the hardness to alkalinity ratio of the raw water. The degasifier will be used to strip the CO₂ formed in the weak acid exchange process.

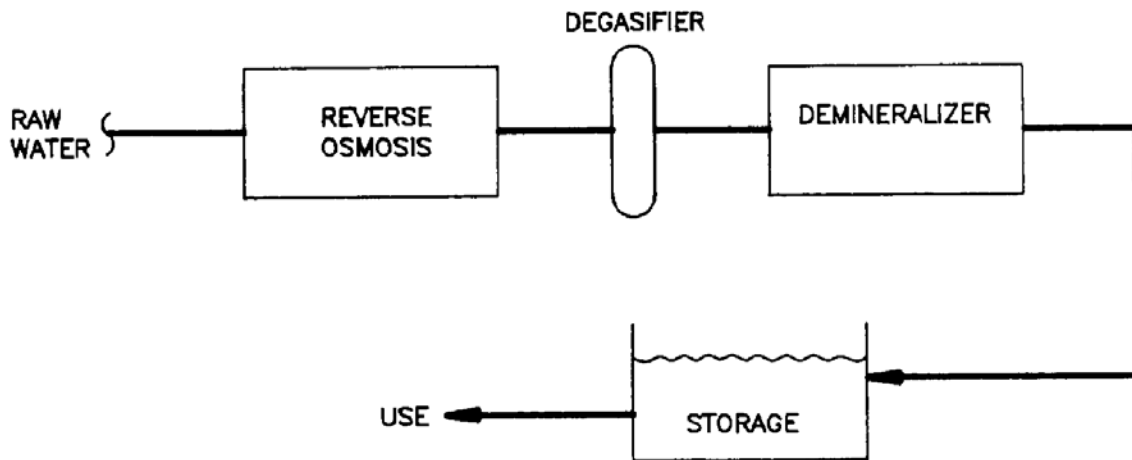

Figure 4

Boiler feedwater treatment with reverse osmosis and demineralizer

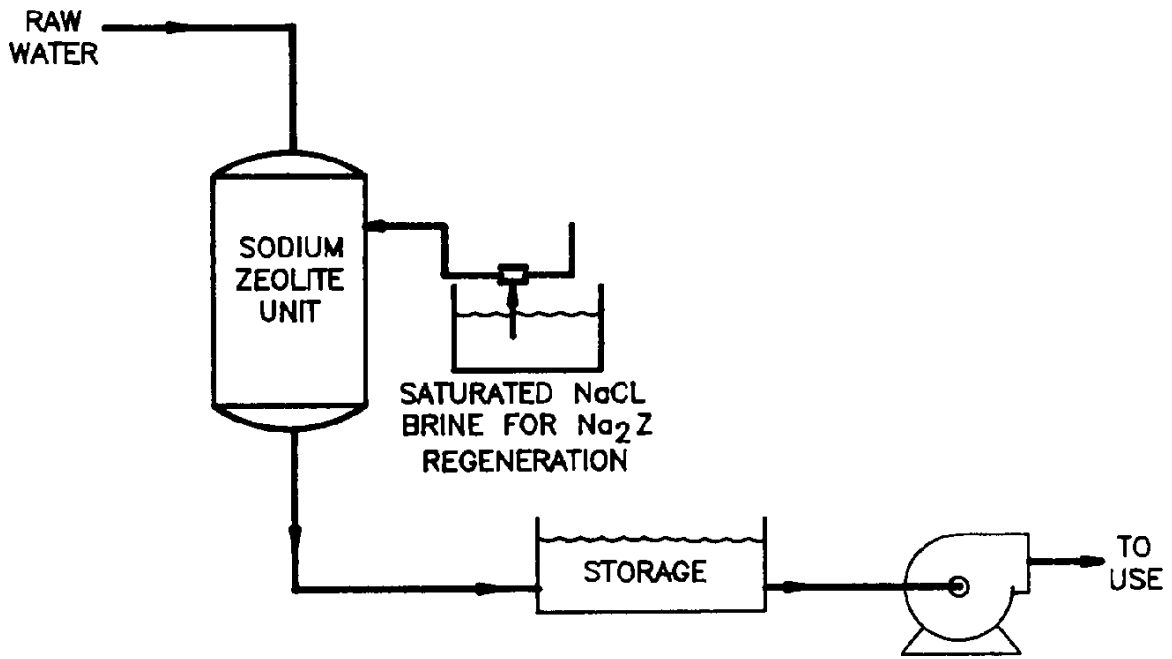

Figure 5
Sodium zeolite unit

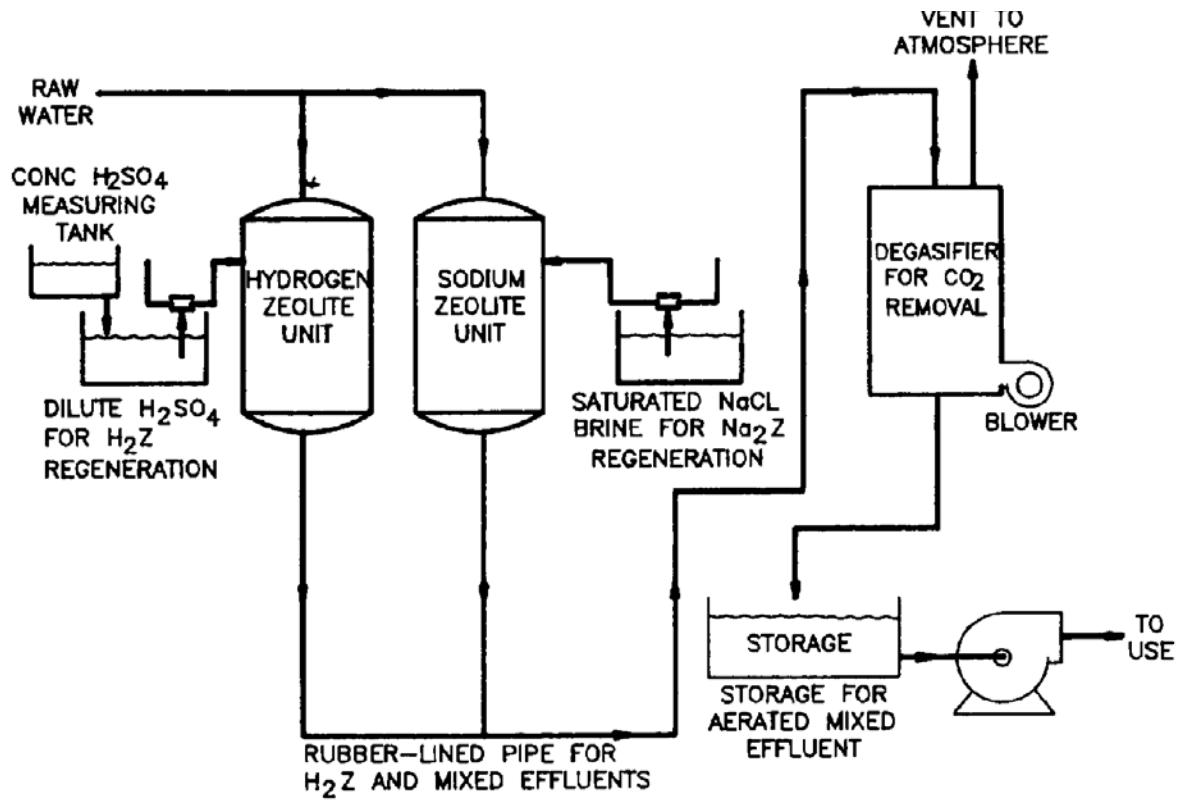

Figure 6

Hydrogen and sodium zeolite units in parallel

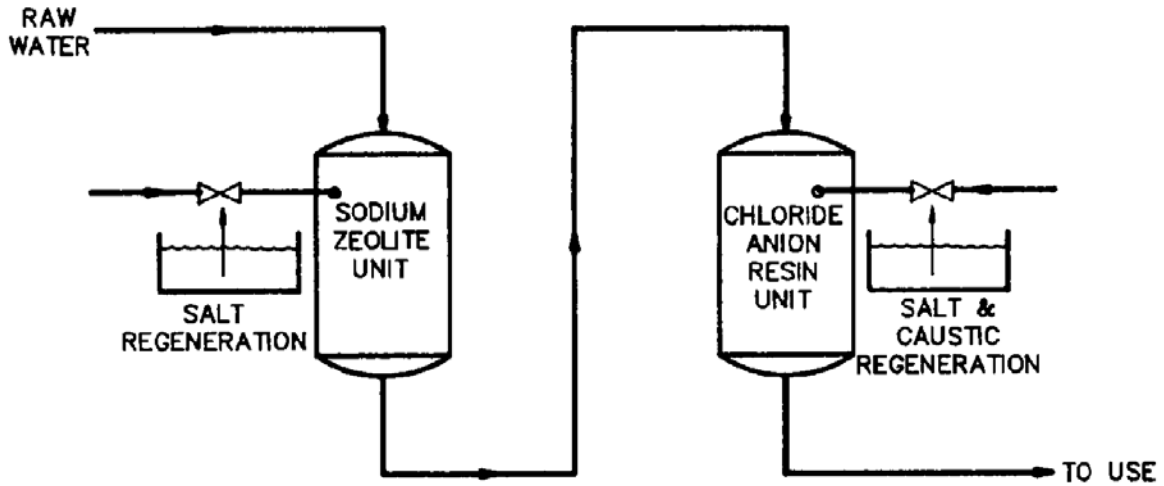

Figure 7

Sodium zeolite – chloride ion exchanger

7.4.6 DEMINERALIZERS produce very high quality water—higher than is generally required for a boiler operating at 400 psig.

8. BLOWDOWN TANK.

8.1 APPLICATION. Pure water vapor is generated in a boiler and the impurities (dissolved solids) of the boiler feed water remain and become concentrated. The concentration of dissolved solids can be controlled by withdrawing the boiler water with a high concentration of dissolved solids as blowdown and discharging it safely to waste through a blowdown tank. Every boiler - system has two types of blowdown. The upper blow-down of either intermittent or continuous operation is used to control concentrations of dissolved solids. It is connected to the steam drum of a water tube boiler in such location as to minimize the inclusion of feedwater, chemical feed and steam entrainment. The other blowdowns from the mud drum or the water walls are intermittent or mass blowdowns which removes accumulated solids and sludge from stagnated areas of the boiler, usually at reduced steam loads. A blowdown tank allows the hot water to flash to steam leaving the concentrated impurities to be more safely drained to waste. The flashed steam can be vented to atmosphere or can be used in a heat recovery system.

8.2 DESIGN.

8.2.1 BLOWDOWN TANKS will be designed and constructed in accordance with the ASM Boiler and Pressure Vessel Code, Section VIII. The amount of boiler blowdown capacity is determined to be a percentage of the boiler firing rate. The percent of boiler blowdown is governed by the allowable concentration ration (CR) or the number of times a dissolved solid may be concentrated over the amount of dissolved solid in the feedwater. The allowable concentration ratios are determined by a chemical analysis of the boiler feedwater and by the type of makeup water treatment. The continuous blowdown rate can be determined using the equation:

$$R = Q * \left(\frac{B}{[A - B]} \right)$$

where

R = blowdown rate (pph)

A = Predetermined boiler water concentration as total solids (ppm)

B = total solids in feedwater to boiler (ppm)

Q = steam output (pph)

A boiler operated on exceptionally high quality feedwater will have very little blowdown. The size of the blowdown tank will be determined from table 7. Blowdown steam and water connection sizes are shown in table 7. The tank will have openings to allow cleaning and inspection. The blowdown tank should have a blowdown inlet connection, a water outlet connection, a vent connection, a cold water supply line, a drain connection, a thermometer connection, and a pressure gauge.

<i>Boiler Design Pressure (psig)</i>	<i>*Blowdown Size (Inches)</i>	<i>Cold Steam Vent Size (Inches)</i>	<i>Water Inlet Size (Inches)</i>	<i>Water Outlet Size (Inches)</i>	<i>**Blowdown Tank Size (Dia x Ht.)</i>
20 to 50	¾	2	¾	1½	14" x 5'6"
	1	2	1	1½	14" x 5'6"
	1½	2	1¼	2½	14" x 5'6"
	1½	2½	1¼	2½	14" x 5'6"
	2	3	2	4	18" x 6'0"
	2½	4	2	4	20" x 6'0"
51 to 100	¾	2	1	1½	14" x 5'6"
	1	2½	1¼	2	14" x 5'6"
	1¼	3	1½	3	18" x 6'0"
	1½	4	2	4	18" x 6'0"
	2	5	2½	4	24" x 6'0"
	2½	6	2½	5	30" x 6'6"
101 to 150	¾	2½	1	2	14" x 5'6"
	1	3	1¼	3	14" x 5'6"
	1¼	4	1½	3	20" x 6'0"
	1½	5	2	4	24" x 6'0"
	2	6	2½	4	33" x 6'0"
	2½	8	3	5	39" x 6'6"
151 to 200	¾	3	1	2	14" x 5'6"
	1	4	1¼	2½	18" x 6'0"
	1¼	5	2	3	24" x 6'0"
	1½	6	2	4	30" x 6'6"
	2	8	2½	4	39" x 6'6"
	2½	8	3	5	48" x 6'6"
201 to 300	¾	4	1¼	2	18" x 6'0"
	1	5	1½	2½	24" x 6'0"
	1¼	6	2	4	30" x 6'6"
	1½	6	2½	4	36" x 6'6"
	2	8	3	5	48" x 6'6"
	2½	10	3	6	54" x 7'0"
301 to 400	¾	4	1¼	2½	20" x 6'0"
	1	5	1½	3	24" x 6'0"
	1¼	6	2	4	33" x 6'6"
	1½	8	2½	4	42" x 6'6"
	2	10	3	5	54" x 7'0"
	2½	10	4	6	66" x 7'0"

Table 7
Blowdown tank size

<i>Boiler Design Pressure (psig)</i>	<i>*Blowdown Size (inches)</i>	<i>Cold Steam Vent Size (Inches)</i>	<i>Water inlet Size (Inches)</i>	<i>Water Outlet Size (inches)</i>	<i>**Blowdown Tank Size (Dia x Ht.)</i>
401 to 500	¾	4	1¼	2½	20" x 6'0"
	1	5	1½	3	27" x 6'6"
	1¼	8	2	4	39" x 6'6"
	1½	8	2½	4	48" x 6'6"
	2	10	3	5	60" x 7'0"
501 to 600	2½	12	4	8	72" x 7'0"
	¾	5	1¼	2½	24" x 6'0"
	1	6	1½	3	30" x 6'6"
	1¼	8	2½	4	42" x 6'6"
	1½	10	2½	5	54" x 7'0"
601 to 800	2	12	3	6	66" x 7'0"
	2½	12	4	8	72" x 7'0"
	¾	5	1¼	2½	27" x 6'6"
	1	6	1½	3	36" x 6'6"
	1¼	8	2	4	48" x 6'6"
801 to 1000	1½	10	2½	5	60" x 7'0"
	2	12	3	6	72" x 7'0"
	¾	6	1¼	2½	30" x 6'6"
	1	8	1½	3	42" x 6'6"
	1¼	10	2½	4	54" x 7'0"
1001 to 1500	1½	10	3	5	66" x 7'0"
	2	12	4	6	72" x 7'0"
	¾	8	1¼	2½	36" x 6'6"
	1	8	2	4	48" x 6'6"
	1¼	10	2½	4	66" x 7'0"
1505 to 2000	1½	12	3	5	72" x 7'0"
	¾	8	1¼	2½	42" x 6'6"
	1	10	1½	4	48" x 6'6"
	1¼	10	2½	5	66" x 7'0"
	1½	12	3	5	72" x 7'0"
2001 to 2500	¾	8	1½	4	48" x 6'6"
	1	10	2	4	66" x 7'0"
	1¼	12	2½	5	72" x 7'0"
	1½	12	3	6	72" x 7'0"

*Size of blow-off connection on boiler or size of blow-off header, whichever is larger.

**The sizes tabulated are based on the minimum diameter and minimum volume that can be used. Larger diameter tanks with equivalent or larger volume may be used.

Table 7 (continued)

Blowdown tank size

8.2.2 THE PRESSURE for which the tank should be designed is shown in table 8. The blowdown tank will have a wear plate between the tank water level and the top of the tank. The blowdown will enter tangentially and the wear plate attached to the shell at the point of impact from the blowdown. The wear plate will be the same thickness of the

tank and extend approximately one-third of the tank circumference. The blowdown tank vent will allow steam to escape from the highest possible location on the tank and will be as direct as possible to the outside atmosphere without intervening stop valves. The water discharge temperature should not exceed 140 degrees F. The pressure of the blowdown leaving any type of blowdown equipment will not exceed 5 psig. The Boiler Law and Rules & Regulations Code administered by the Bureau of Safety & Regulation in Lansing, Michigan can be used as a guide in designing blowdown tanks. Each state will be consulted to determine their design criteria.

9. BLOWDOWN HEAT RECOVERY.

9.1 APPLICATION. A LCCA will be conducted to determine if a blowdown heat recovery system is a justifiable capital investment.

9.2 DESIGN. Heat is recovered in a blowdown heat recovery system by passing the blowdown water from the blowdown tank through a heat exchanger to recover the sensible heat of the water and transferring blowdown tank steam to the DA. The heat exchanger will be sized to reduce the temperature of the blowdown main to 20 degrees F above the inlet temperature of the fluid being heated, typically feedwater heating, makeup water heating, building heating, oil heating or process steam generation. The blowdown tank for a heat recovery system will be smaller to allow the blowdown drain water to be hotter for an effective heat recovery system. If flash steam is used in the DA, the blowdown tank will be designed to minimize carryover. A normal blowdown system consisting of a large blowdown tank venting to atmosphere and draining directly to waste may have to be available to allow maintenance on the heat recovery equipment during operation. There are several package blowdown heat recovery systems available consisting of blowdown tanks, heat exchangers, flow control valves, thermostatic control valves, sample coolers and high level float switches.

<i>Maximum Allowable Boiler Pressure, psig</i>	<i>Blowdown Tank Design Pressure, psig</i>
50	25
100	50
200	70
300	90
500	125
750	165
1000	200
1500	275
2250	325
2500	400

Table 8
Blowdown Tank Pressure

10. STEAM COIL AIR HEATER.

10.1 APPLICATION. The steam coil air heater preheats the combustion air before it enters the main air heater. The heat dries the air and reduces corrosion of the air heater tube metals.

10.2 DESIGN. The installation will be designed for reasonable air velocities with pressure loss not to exceed one inch of water. The heating coils will be designed in multiple elements to maintain average cold and metal temperatures of the air heater surfaces above 180 degrees F at all loads up to 15 percent above full rated load. The uncorrected air heater gas outlet temperature should be used to determine the average cold end metal temperature. A typical steam coil would have seamless type 321 stainless steel tubes, outer tubes 1 inch outside diameter and 0.049 inch minimum wall thickness and inner tubes 5/8 inch outside diameter and 0.022 inch minimum wall thickness. The supply and return connections are to be on the same end of the coil. Tubes will be pitched to the drain. The coil should be removable in a manner that does not disturb connecting ends of breeching. The coil outer casing is typically 10 gauge steel welded into an airtight structure. The core header plate will be gasket sealed to the casing.

11. STEAM COIL DRAIN TANK.

11.1 APPLICATION. The steam coil drain tank will collect the condensate from the steam coil air heater for transfer to the DA.

11.2 DESIGN. The steam coil drain system must be sized large enough to drain the maximum expected steam flow rate to the air heater and to maintain a reasonable condensate level allowing proper operation of the steam coil drip return pumps (if included). Another consideration is the possibility of freezing. The steam coil tank should be located indoors, if possible, and sized small enough that outdoor drain piping is not allowed to fill with condensate. The steam coil drain tank is normally equipped with a level controller, gauge glass and high level alarm. The steam coil drain tank will be designed and constructed in accordance with the ASME Boiler and Pressure Vessel Code, Section VIII.

12. FANS.

12.1 APPLICATIONS. Boiler furnaces are either pressurized or have balanced draft for combustion. Gas and oil fired boilers are normally of the pressurized furnace design. Modern coal fired boilers have balanced draft type furnaces. Balanced draft type boilers use FD fans to supply combustion air to the furnace and ID fans exhaust the products of combustion or flue gas. The furnace is kept at a slightly negative pressure ranging from 0.1 to 0.25- inches w.g., by the ID fan which is located downstream of the particulate removal equipment.

12.2 FORCED DRAFT FANS. FD fans operate with reasonably clean, cool or warm air and will be designed for quietness and efficiency. This source of combustion air is frequently taken from within the steam plant to promote ventilating and to take advantage of the higher ambient temperatures. Inlets for the fans will have silencers with screens to attenuate entrance noises and to keep birds and other objects from entering the system. The static pressure of the FD fan will be calculated for the pressure drop through the inlet air duct, steam coil air heater, air heater (if used), air metering devices, dampers or vanes, air ducts, static fuel bed or burners and any other resistance between the fan and the furnace at the air flow rate required for proper combustion. The volume of the air to be handled is dependent on the air pressure (elevation), moisture content if moisture exceeds 1 or 2 percent by weight, temperature and excess air required. Factors of safety to be added to the air flow requirements to obtain test blockrating are 20 percent excess volume and 32 percent excess pressure for coal fired boilers. Add 25 degrees F to temperature of the air being handled as a safety factor.

12.2.1 FD FAN will be airfoil type to provide lower power consumption. Airfoil fans will have inlet vane controls to provide low part load power consumption.

12.2.2 FD FAN DESIGN will include the following features. Shafts will be designed to have critical speeds not less than 1.4 times the operating speed. Bearings will be antifriction type with L10 life of 100,000 hours. Wheel stresses should not exceed 50 to 60 percent of yield strength while using finite difference methods and 75 percent of yield strength at operating temperature while using finite element methods. Stress rupture should be considered for elevated temperature. Variable speed fan fatigue life should be evaluated to avoid premature failure due to low cycle fatigue. An impact response test should be performed to avoid high cycle fatigue due to resonance. Resonance speed of fan support system should not be less than 1.2 times operating speed.

12.2.3 INDUCED DRAFT FANS. ID fans can operate under erosive conditions even though these fans are located downstream of the particulate (fly ash) collection equipment. Erosion is controlled by using abrasion resistant material and limiting top speed. The ID fans move the gas from the furnace, through the superheater if required, boiler bank, economizer, ductwork, scrubbers, baghouse and stack. Corrosion must be considered if temperatures of flue gas are within 30 degrees F of the dew point. The type of fan is usually straight radial with shrouds (modified radial) or radial tip design (forward curved, backward inclined) with wearing strips when dust burden is high. Maximum speed should be 1200 revolutions per minute (rpm). Even when flue gases are normally cleaned through a baghouse before they reach the fan dirty gases can be bypassed around the baghouse and impinge on the fan blades or wheel. Therefore, the fan must be constructed to resist fly ash and dust buildup and to give better wear resistance. Factors of safety to be added to the air flow requirements to obtain test block rating are 20 percent excess volume and 32 percent excess pressure for coal fired boilers. Add a minimum of 25 degrees F to the temperature of entering gas being handled as a safety factor. ID fan type will be selected based on grain loading according to table 9. ID fan control type will be selected based on temperature and grain loading according to Table 10. ID Fan design will include the following features. Shafts will be designed to have critical speeds not less than 1.4 to 1.5 times the operating speed. Bearings shall be antifriction type with L10 life of 100,000 hours.

Partial liners will be included for airfoil or backward curved fans. Partial or full width liners will be included for other blade types based on dust loading and velocities. Housings will be provided with liners or replaceable heavier scroll for fans with severe dust loading. Wheel stresses should not exceed 50 to 60 percent of yield strength while using finite difference methods and 75 percent of yield strength at operating temperature while using finite element methods. Stress rupture should be considered for elevated temperature. Variable speed fan fatigue life should be evaluated to avoid premature failure due to low cycle fatigue. An impact response test should be performed to avoid high cycle fatigue due to resonance. Resonance speed of fan support system should not be less than 1.25 times operating speed.

<i>Grains/actual cubic feet</i>	<i>ID fan type</i>
0.1 to 0.2	Airfoil
>0.2	Radial tipped, backward inclined, or radial bladed

Table 9
ID fan type

<i>Temperature</i>	<i>Grains/actual cubic foot</i>	<i>Type ID fan control</i>
≤500 F	≤0.2	inlet vane
>500 F	>0.2	inlet box dampers

Table 10
ID fan control type

12.2.4 FAN CONTROL METHODS.

12.2.4.1 DAMPERS are used on the fan discharge at either the stoker plenum, the boiler outlet or in ducting and function to raise system resistance, thus raising operating points higher on the fan curves and altering fan output. Input power can decrease somewhat on decreased volume output if fan efficiency increases. Dampers are closed on startup of the boiler to reduce the starting load on the motor.

12.2.4.2 VARIABLE INLET VANES are used to change characteristic curves of FD fans. Vanes impart a pre-spin to the gas and by the alteration of the pitch of the vanes, fan discharge volume and pressure are changed to give new system operating points. With fixed speed motors, power usage only slightly diminishes as air volume is reduced; this system will operate economically if air volume is 75 percent or above the design volume. Movement of vanes is nonlinear so they have to move more at low loads.

12.2.4.3 TWO SPEED MOTORS, generally of speed ratios of 4:3 or 3:2 with variable inlet vanes will provide economical operation down to 40 percent of the design volume.

12.2.4.4 VARIABLE SPEED DRIVE on ID fan, two speed or variable speed motor on FD fan, with variable inlet vanes on boiler outlet damper, are generally required for most efficient operation of heating plant boiler systems with power drive requirements in excess of 10 hp. The benefits of a variable speed drive are greater when the boiler is operated at lower loads. A life cycle cost analysis (LCCA) should be performed based on the number of hours at each load to justify the use of a variable speed drive. The variable speed gives an infinite series of fan curves from which the points of highest system efficiency can be chosen. Fans with both adjustable speed capability and control inlet vanes provide the most energy efficient operation. Control dampers may be provided for multiple coal fired units with auxiliary oil firing for startup of boiler and adjustment of air flow. If oil is fired in a boiler designed for coal firing, excessive

dampening may set up objectionable vortexing of the air currents in the breeching and ductwork unless variable speed drives are used in the system.

12.2.5 FAN MOTORS. Motors will be selected for the maximum duty required by the fan under most severe anticipated operating conditions.

13. HYDRAULIC ASH HANDLING PUMPS.

13.1 APPLICATION. Bottom ash can be conveyed hydraulically from a bottom ash hopper by means of mechanical pumps.

13.2 ASH SLUICE PUMP.

13.2.1 APPLICATION. The ash sluice pump pumps recycle sluice water through the bottom ash hopper outlet to be disposed.

13.2.2 SIZING. Two 100 percent capacity pumps will be used to provide full backup. The capacity of the ash sluice pumps will depend on the hydraulic ash handling system demands. The discharge head of the ash sluice pump will be designed to overcome the piping losses and static head to a dewatering bin or surge tank. A jet pump hydraulic system will demand higher pressure pumps to allow the jet pump to function properly. A surge tank is required to make available adequate NPSH for an effective pump.

13.2.3 CONSTRUCTION. The pumps will be constructed in a horizontal split case configuration with a heavy duty slurry type enclosed impeller. Replaceable shaft sleeves, suction sideplates and rear sideplates will be provided. The pump will include oil lubricated bearings and a stuffing box packing for external clean water injection.

13.2.4 PUMP MATERIALS. Ash sluice pumps will be designed of abrasion resistant alloys to provide an acceptable life.

13.3 BOTTOM ASH PUMP.

13.3.1 APPLICATION. The bottom ash pump transfers the slurry from the bottom ash hopper discharge to a disposal area, either dewatering bins or ash handling ponds. The

bottom ash pump is not needed if the ash sluice pumps are designed to pump the water through the hopper discharge to the disposal system.

13.3.2 SIZING. The bottom ash pump is most generally used with a surge tank downstream of the ash hopper offering a controlled NPSH. Two 100 percent capacity pumps will be used to provide full backup. The capacity of the bottom ash pumps depend on the hydraulic ash handling system demands. The capacity must be greater than the ash sluice pump capacity. The discharge head of the bottom ash pump will be designed to overcome the piping losses and static head to a dewatering bin.

13.3.3 CONSTRUCTION. The pumps will be constructed in a horizontal, vertical split case, end suction back pullout configuration with a heavy duty, slurry type enclosed impeller. Replaceable shaft sleeves, suction sideplates and rear side-plates will be provided. The pump will include oil lubricated bearings and a stuffing box packing for external clear water injection.

13.3.4 PUMP MATERIALS. Bottom ash pumps will be designed of abrasion resistant alloys to provide an acceptable life.

13.4 ASH SLUICE WATER RECIRCULATION PUMPS.

13.4.1 APPLICATION. Ash sluice water recirculation pumps are used for returning ash pond water to a surge tank for the ash sluice pump suction.

13.4.2 SIZING. Two 100 percent capacity pumps will be used to provide full backup. The capacity of the recirculation pumps must exceed the ash sluice pump capacities. The NPSH available will be the atmospheric pressure of the ash pond plus the depth of the impeller minus the resistance of the suction bell piping. The discharge head of the recirculation pumps must overcome piping losses and the surge tank static head.

13.4.3 CONSTRUCTION. The pumps will be vertical shaft configuration with bottom suction. Replaceable suction sideplates and rear sideplates will be provided.

13.4.4 PUMP MATERIALS. The ash sluice water recirculation pumps will be designed of abrasion resistant alloys to provide an acceptable life.

13.5 SLUDGE RETURN PUMP.

13.5.1 APPLICATION. The sludge pump is used on a hydraulic handling system using a dewatering bin. A tank or series of tanks collect and store the water discharge from the dewatering bins. Remaining ash particles settle in these conical shaped tanks and are pumped from the tank bottom back to the dewatering bins by sludge return pumps

13.5.2 DESIGN. The sludge return pumps have the same design characteristics as the bottom ash pumps.

14. ELECTRIC COOLING WATER PUMPS.

14.1 APPLICATION. Bearing cooling water pumps will supply cooling water to all plant equipment with a cooling water demand. Typical equipment requiring cooling water are pulverizers, pump bearings and seals, air compressors and after coolers, fan drives, lube oil coolers and chemical feed sample coolers, boilers access doors and scanning fire detectors. Smaller boiler plants may have processed water available and may not require cooling water pumps. Boiler plants with a plentiful water supply will sometimes allow cooling water to be discharged without recirculation.

14.2 DESIGN. Two 100 percent capacity pumps will be used to provide full backup. The required flow rate needed is found by adding all equipment coincident demands. The future expansion of the plant will also be considered. The cooling water system may be an open (once through) or closed (recirculating) type of system depending on the availability of clear water. The system head required must be determined by adding the system piping friction losses and the static head required. When the flowrate and total head required are known, add 10 percent to the total head for wear allowance. This will be the rated capacity and total dynamic head for the pump selection.

14.3 CONSTRUCTION. The pumps will be motor driven, horizontal, vertical split case, end suction, centrifugal type, back pullout configuration, single stage design.

15. BEARING COOLING WATER HEAT EXCHANGERS.

15.1 APPLICATION. Bearing cooling water heat exchangers are required for a closed loop system in which clean water is not available in unlimited quantities. A heat exchanger will transfer heat absorbed by the clean bearing cooling water and transfer it to a circulating water system. The circulating water system may use river water, lake water, or a cooling tower system where absorbed heat can be discharged. An evaluation must be made to determine the feasibility of using a heat exchanger versus using a cooling tower where bearing water is directly pumped through the cooling system. A plentiful supply of dirty water from a lake or river may make a heat exchanger more economical. Consideration will be given to water treatment as a cooling bearing water system would have to be constantly monitored and treated as water is made up for evaporation.

15.2 DESIGN. The heat exchanger must be sized to transfer all the heat generated from the fully operational plant at the maximum continuous rating. Two heat exchangers will be used so one can be removed from service, each having 100% of the flow capacity. The heat exchanger will be designed to conform to the ASME Boiler and Pressure Vessel Code, Section VIII. The heat exchanger manufacturer must be given the information for both the shell side and the tube as shown in table 11. The amount of cooling water required depends on the equipment cooling water demand. The equipment manufacturers will be asked how many gallons of cooling water per minute is required for equipment cooling at a given inlet temperature of 95 degrees F allowing the outlet temperature to be no more than 10 degrees F higher. The heater cooling water rated flow capacity will be the total equipment demand of all equipment to be operating simultaneously plus a 20 percent design margin. The circulating water rated flow capacity will be twice the cooling water rated flow capacity.

15.3 CONSTRUCTION. The coolers will be designed and constructed to conform with the ASME Boiler and Pressure Vessel Code, Section VIII.

	<i>Typical Values</i>	
	<i>Shell Side</i>	<i>Tube Side</i>
	<i>Cooling Water</i>	<i>Water</i>
Number of passes	.1	1
Temperature in, degrees F	115	85
Temperature out, degrees F	95	95
Flow gpm.	demand	demand
Maximum pressure drop, psi	2	5
Design pressure, psig	150	75
Fouling factor	.0005	001
Maximum velocity, fps	3.0	5.0

Table 11
Heat exchanger design information

The construction of the coolers will allow the circulating water or dirtier water to pass through the tubes allowing more practical cleaning. The cooler tubing and tube sheet material selection will be based on water quality. Materials can be admiralty, copper nickel, or for corrosive applications stainless steel. The coolers will be the straight tube type with fixed tubesheet, removable channel construction. The shell will be carbon steel and the channel heads will be fabricated steel. The shell will have 150 pound raised face flanged or 3000 pound screwed connections. The channel will have 150 pound flat faced flanged or 3000 pound screwed connections. The coolers will be manufactured with shell, channel vent and drain connection.

16. IGNITOR FUEL OIL PUMPS.

16.1 DESIGN. Ignitor fuel oil pumps will be rotary screw type pumps. Two pumps will be provided, each rated at 100 percent capacity, with one pump used for backup service. A fuel oil unloading pump will be applied if required and will have the same characteristics as the ignitor fuel oil pumps. No. 2 fuel oil is more commonly used for ignitor systems and will be assumed herein. The pumps will be able to pump oil with a viscosity of 200 Saybolt Seconds Universal (SSU) against the design discharge pressure at the design capacity. Fuel oil viscosity will be expected to vary between 33 and 200 SSU. Pump motors will be totally enclosed and explosion-proof.

B. TYPES. Unlike a centrifugal pump, a rotary screw pump is a positive displacement pump that will displace its capacity to the point of failure regardless of the resisting pressure. A fuel oil recirculation system will be designed to allow the pump to recirculate the fuel oil as the ignitor fuel oil is modulated according to demand. In a fuel oil loading system the fuel oil is not modulated and a recirculation system is not necessary. In sizing the fuel oil pump, the pressure to overcome will be Codes calculated from piping losses and elevation change to get the required pump discharge pressure. The ignitor fuel oil pump capacity is determined from maximum fuel oil demand plus 20 percent for pump wear and safety factor.

17. NITROGEN SYSTEM.

17.1 APPLICATION. The nitrogen system is used to purge the boiler for protection from corrosion between hydrostatic test and initial operation and after chemical cleaning periods and outages.

B. DESIGN. The boiler steam parts are filled with treated water until overflowing and then capped off with 5 psig of nitrogen according to the recommendations of the boiler manufacturer. Depending on the boiler and down period, such steam parts filled with treated water or a nitrogen purge are the economizer, water walls, superheater, reheater, feedwater heater (tube side-water; shell side nitrogen) and drum. In some cases freezing may be a problem and treated water can be replaced with nitrogen. The amount of nitrogen required, for boiler purging will be given by the boiler manufacturer or can be calculated from the volume of the steam parts. The nitrogen system is a low pressure system. However, the nitrogen is stored in high pressure cylinder bottles and the piping will be connected to a high pressure boiler. A pressure regulator and high pressure valving will be required.

18. CARBON DIOXIDE (CO₂) SYSTEM.

18.1 APPLICATION. A carbon dioxide system in a boiler plant is most commonly used to extinguish fires in coal bunkers. A CO₂ system can also be used to extinguish electrical hazards, such as transformers, oil switches and circuit breakers, and rotating equipment. CO₂ extinguishes fire by reducing the concentration of oxygen and the gaseous phase of the fuel in the air to the point where combustion stops.

18.2 DESIGN. The CO₂ systems are classified as automatic, manual or automatic-manual. Fires or conditions likely to produce fires may be detected by visual (human senses) or by automatic means. In the case of coal bunkers, methane detectors can be used to alarm a fire or actuate the CO₂ system and an alarm. CO₂ can be stored in cylinder bottles and pipes through a pressure regulated system to discharge nozzles at the area of combustion. The amount of CO₂ in the system will be at least sufficient for the largest single hazard protected or group of hazards to be protected simultaneously. The CO₂ system will be designed and erected in accordance with NFPA 12 of the National Fire Codes.

19. CHEMICAL FEED PUMPS.

19.1 APPLICATION. Chemical feed pumps are small capacity pumps used to inject chemicals into the condensate, feedwater and steam system at a controlled rate. Most chemical feed pumps are specified and purchased as a chemical feed unit that includes a pump, tank, mixer and piping. Typical chemical systems used in a boiler plant are hydrazine, morpholine, phosphate and a metal surface passivating agent.

19.2. DESIGN. The pump selection will have the capacity and discharge head to inject the chemical into the system. Pumps are rated by capacity in gallons per hour (gph), discharge head in psig and piston strokes per minute. The chemical feed pumps will be positive displacement metering type. The pumps will have hydraulically balanced diaphragms, mechanically actuated air venting; all rotating parts to run in an oil bath with roller bearings; double ball check valves with Teflon O-ring seats on both suction and discharge. The pumps will have micrometer capacity adjustment from 0 -100 percent while the pump is running and to have metering accuracy within plus or minus 1 percent.

19.3 CHEMICAL FEED UNIT. Chemical feed tanks for the mentioned chemicals will be 16 gage type 304 stainless steel with agitator, gage glass and low level alarm system. Piping will be stainless steel and valves will have Teflon seats. The chemical feed system will include a back pressure valve to insure accurate and consistent metering at all flows and will include a safety valve.

20. LABORATORY.

20.1 GENERAL. A laboratory is needed in every boiler plant to assist in analyzing chemical treatment and in early detection of problems. Samples of water and steam are taken from various systems and parts of systems to evaluate the system*s condition.

20.2 SAMPLE COOLERS. Sample coolers are required to condense steam and cool water to be handled. Sample coolers are heat exchangers that will be sized to maintain the temperature at 77 degrees F. Coolers for individual samples are either double tube helical coils with cooling water counterflow cooling or submerged helical coils properly baffled to effect counterflow cooling. If a coil type of exchanger or a coil and condenser type of exchanger are used, they will meet the intention of ASTM D 1192. If a multicircuit heat exchanger is used, it will meet the requirements of Section VIII, ASME Boiler and Pressure Vessel Code.

21. SUMP PUMPS.

21.1 APPLICATION. Sump pumps are required in several applications at a boiler plant. Sump pumps primarily are used for storm water removal but also are used for ash hopper water overflow or any condition requiring removal of water from a sump.

21.2 DESIGN. The pump will be sized for one and one-half times the maximum amount of expected drain rate. Two 100 percent capacity pumps will be used to supply full backup if overflow is dangerous. The suction line between the suction vessel and the pump must be properly designed to prevent air pockets and cavitation. Sufficient NPSH must be available at the pump suction flange.

21.3 CONSTRUCTION. The pumps will be motor driven, vertical shaft configuration with bottom suction and open impeller. The pump will include a flanged column, discharge pipe flanged over soleplate, bearing lubrication piping and connections on the soleplate to support the pump and motor.